

DC/DC Converter Converter pre Charger

1kW

1 KLB 110 M600 W00

$V_{In,nom} = 110\text{ V}$

$V_{O,nom} = 600\text{ V}$

$I_{O,nom} = 2.5\text{ A}$

SYMBOL	PARAMETER	TEST CONDITIONS	MIN	TYP	MAX	UNIT
INPUT						
V_{In}	Operating input voltage range	continuously	77		137.5	V_{DC}
V_{In}	Acc. EN 50155	Dynamic $t \leq 0.1s$ $t \leq 1.0s$	66 137.5		77 154	V_{DC} V_{DC}
$V_{In\ min}$	Converter ON	$0\text{ A} \leq I_o \leq 2.5\text{ A}$	55	60	65	V_{DC}
$V_{In\ min}$	Converter OFF	$0\text{ A} \leq I_o \leq 2.5\text{ A}$	50	55	60	V_{DC}
$V_{In\ max}$	Converter OFF	$0\text{ A} \leq I_o \leq 2.5\text{ A}$	155		160	V_{DC}
	Stand by current	$77\text{ V} \leq V_{In} \leq 154\text{ V}$, Enable = OFF			3.0	mA
I_{In}	Input current: no load at output	$V_{In} = 154\text{ V}$, $I_o = 0\text{ A}$		100	120	mA
I_{In}	Input current: no load at the output charging load	$V_{In} = 154\text{ V}$, $I_o = 0\text{ A}$ $V_{In} = 137.5\text{ V}$, $I_o = 2.5\text{ A}$ $t < 3s$ $V_{In} = 110\text{ V}$, $I_o = 2.5\text{ A}$ $t < 3s$ $V_{In} = 77\text{ V}$, $I_o = 2.5\text{ A}$ $t < 3s$		50 12 15 16	100	mA A A A
	Inrush current Integral	$V_{In} = 154\text{ V}$			10	A ² s
$I_{In\ max}$	Max. input current	$V_{In} = 77\text{ V} \dots 154\text{ V}$, $I_o = 2.5\text{ A}$ $\Delta t \leq 250\text{ ms}$		16	19	A
	Input fuse	yes	20 AT			
C_{In}	Input capacity			20	30	μF
	Max. allowed external line inductance				50	μH
	Input reverse protection	yes	- 154.0			V_{DC}
	Input transient protection	bidirectional transil diode	BZW50 - 150B			

OUTPUT: Power Stage

$50.4\text{ V} \leq V_{In} \leq 137.5\text{ V}$

P_o	Output power	$T_A = -40^\circ\text{C} \dots +70^\circ\text{C}$		1.000		W
$V_{O\ nom}$	Output voltage: factory adjust		575	600	615	V_{DC}
ΔV_o	Output voltage regulation TL 431 @ ΔT , t (aging)	$0\text{ A} \leq I_o \leq 2.5\text{ A}$ $T_A = -40^\circ\text{C} \dots +70^\circ\text{C}$ $T_A = +70^\circ\text{C} \dots +85^\circ\text{C}$	$\leq 2.5\%$ von $V_{A\ nenn}$ $\leq 3.0\%$ von $V_{A\ nenn}$			
$\Delta V_{O\ dyn.}$	Load regulation	Load: 20 - 80 - 20 % $\times I_{O\ nom}$		1	2.5	V
t_{dyn}	Response time	Load: 20 - 80 - 20 % $\times I_{O\ nom}$		1	3	ms
$V_{O\ rms}$	Ripple voltage	Nominal load BW 300 kHz		100	500	mV _{rms}
$V_{O\ ss}$	Spikes	Nominal load BW 20 MHz			250	mV _{pp}
t_{on}	Switch ON time V_o	$0\text{ A} \leq I_o \leq 2.5\text{ A}$ capacitive load $0\text{mF} < C < 7.5\text{ mF}$ (Opt. 10 - 22mF)	1.8	2.0	2.75	s
	Overvoltage switch OFF $V_{Out,max}$	$0\text{ A} \leq I_o \leq 2.5\text{ A}$	converter OFF: $V_o \leq 690$			V_{DC}
I_o	Output current	$T_{Amb} = -40^\circ\text{C} \dots +85^\circ\text{C}$ class Tx	2.25	2.5	4.0	A
	Threshold value current limitation	$T_{Amb} = -40^\circ\text{C} \dots +70^\circ\text{C}$	2.6			A
C_{out}	Internal capacity			6		μF
$\vartheta\ Tr.$	Transformer over-temperature switch OFF		100	105	110	$^\circ\text{C}$

ENABLE&SIGNALLING

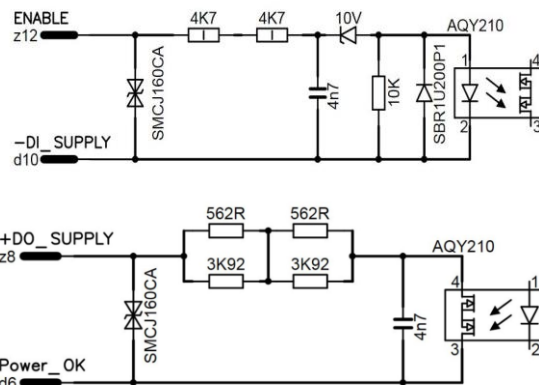
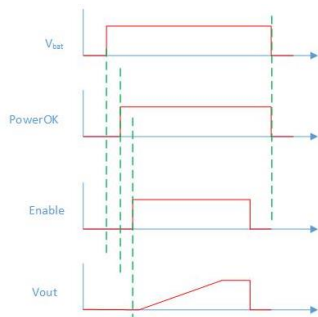

COMMON DATA

f	Switching frequency	$V_{In} = 110\text{ V}$, $I_o = 2.5\text{ A}$	40	75	140	kHz
η	Efficiency	$P_{out} \geq 0,7 \times P_{out\ nom}$	85	88		%
	MTBF (SN 29500)	$V_{In} = 110\text{ V}$, $I_o = 2.5\text{ A}$, $T_A = +40^\circ\text{C}$		400 000		h
	No load- & short circuit proofed	continuously		yes		

DC/DC Converter Converter pre Charger

1 KLB 110 M600 W00

SYMBOL	PARAMETER	TEST CONDITIONS	MIN	TYP	MAX	UNIT
SAFETY / DIMENSIONS						
	Clearance - and creepage distances for PD2, OV2 *) PCB FR4, V0, T _G = + 140°C (+150°C on request), IPC 6012E class 3	input output input housing output housing	40 20 20			mm mm mm
	Isolation voltage Unit test: ramp function 2s - 3s - 2s Type test: 1 minute	input output input housing output housing			6'000 4'500 1'500	V _{DC} V _{DC} V _{DC}
	Isolation resistance	input output	30			MΩ
	Connector	input Harting H15 male DIN 41612 necessary mating connector female	H15			
	Protection degree, - class	SE M6 Al – Metal housing	I, IP 30			
	Dimensions B x H x T	DC/DC converter	241 x 184 x 84.5			mm
	Mounting	Wall mounting with screws	6 x M6			
	Weight	Converter		1.8		kg

AMBIENT CONDITIONS

T _A	Operating temperature range	EN 50155 class Tx 10 min.	- 40 + 70		+ 70 + 85	°C °C
T _{Store}	Storage temperature range		- 40		+ 85	°C
	Cooling		Free convection			
	Humidity	EN 50155, IEC 60571	75% averaged per year, 95% 30 days			
	Vibration / Shock	IEC 61373, IEC 68-2-27 category I: 3 shocks each axis	50 m / s ² , 30 ms			

EMC

	Emission	Line referenced and radiated	EN 50121 - 3 - 2: 2016			
	Immunity	ESD EN 61000 - 4 - 2	6 kV / 8 kV Performance criteria - B -			
		High frequency HF-Field **) EN 61000 - 4 - 3	20 V / m 80 MHz ... 1 GHz Performance criteria - A -			
		Burst EN 61000 - 4 - 4	Level 3 asym., sym. Performance criteria - A -			
		Surge EN 61000 - 4 - 5	2 kV asym. / 1 kV sym. R _i = 42Ω, Performance crit.- A-			
		HF – current injection EN 61000 - 4 - 6	10 V _{eff} , R _i = 150 Ω Performance criteria - A -			

referenced standards:	EN 50155: 2016	EN 60529	EN 50124 - 1: 2006	EN 50121 - 3 - 2: 2016	IEC 60571
	SN 29500	EN 50121 - 1	EN 50125 - 1	EN 60068 - 2 - 6, 2...27	EN 61000 - 4 - 2...6
	IEC 571	IEC 61373: 1999	EN 60721 - 3 - 5	EN 61373 : 1999	EN 45545-2
**) 20 V/m 80 MHz - 1000 MHz 1400MHz – 2000MHz 10V/m 2000MHz – 2700 MHz 5V/m 5100MHz – 6000MHz 3V/m					

Pin		recommended wiring size
z24	+ V _{In}	2.5 mm ²
d22	+ V _{In}	2.5 mm ²
z32	- V _{In}	2.5 mm ²
d30	- V _{In}	2.5 mm ²
z12	ENABLE	1.0 mm ²
d10	DI Supply	1.0 mm ²
z8	DO Supply	1.0 mm ²
d6	Power OK	1.0mm ²
Output X2 Screwing 2 bolts		
	+ V _{out}	M6
	- V _{out}	M6
Earth M6 screwing 1 bolt		

